

CHANGE			
版本 EDITI	变更内容 MODIFICATION	变更日期 UPDATE DATE	签名 SIGNATURE

NOTES:

1. Operation Temperature: -40°C ~ +85°C.
2. Electrical Characteristics:
 - 2.1>Rated Current: 125V AC, 1.5A@25°C.
 - 2.2>Contact Resistance: 20mΩ Max.
 - 2.3>Insulation Resistance: 500MΩ Min, 100V DC/min.
 - 2.4>Voltage Proof: 1000V AC/1 minute no breakdown.
3. Mechanical Characteristics:
 - 3.1>Insertion Force & Withdrawal Force: 30N Max.
 - 3.2>Durability: 750 cycles Min.
4. Environmental compliance:
 - 4.1>the products are compliant with the RoHS, and REACH etc.

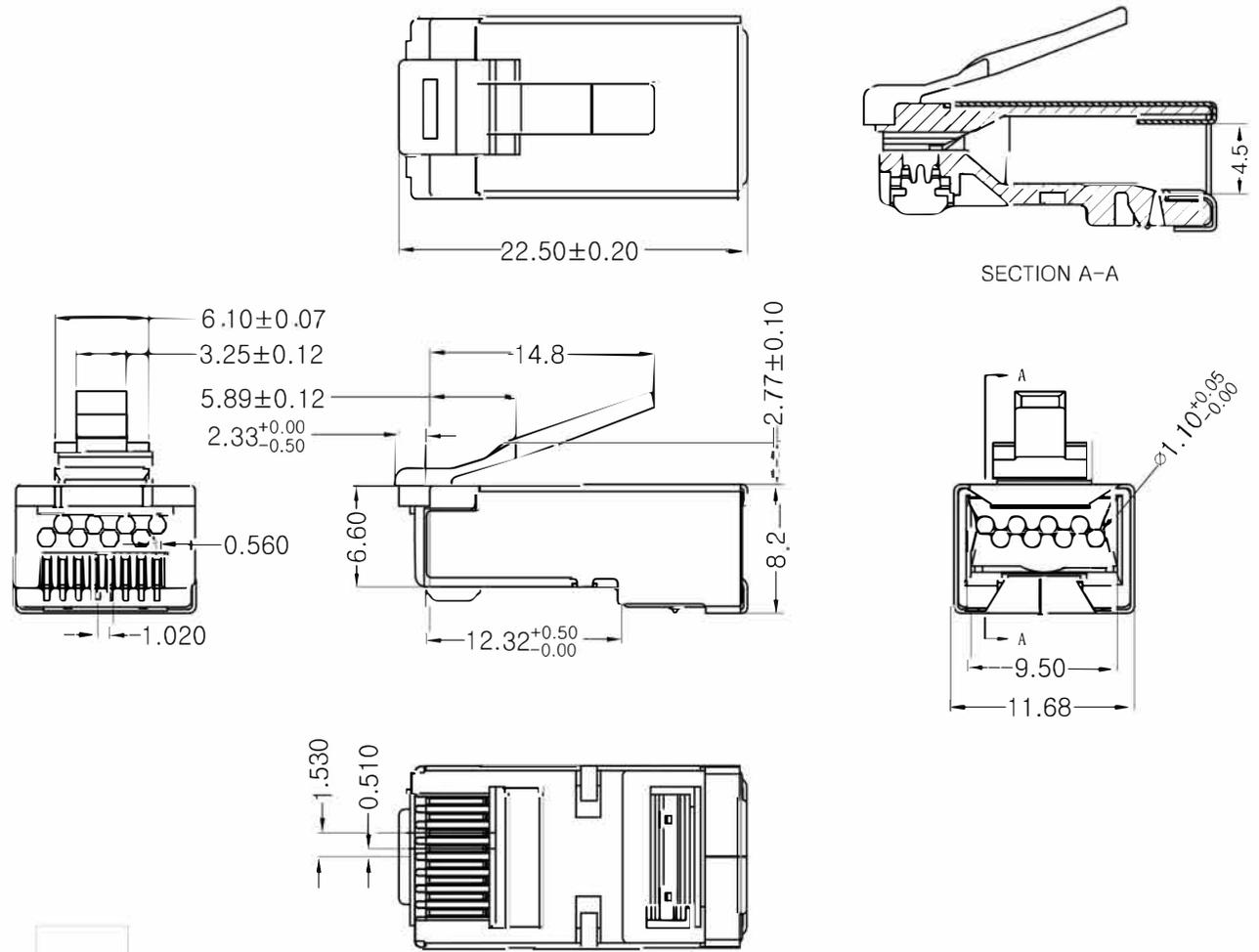

1	水晶头 Modular Plug	屏蔽壳 Shell	1PCS	43*20**09	方孔 Square hole	Au: G/F" <input type="checkbox"/> 1u" <input type="checkbox"/> 3u" <input type="checkbox"/> Ni: 80u" <input type="checkbox"/>	黄铜 <input type="checkbox"/> 铁 <input type="checkbox"/> Brass Spcc
		金片 Contacts	8PCS	/	2叉 <input type="checkbox"/> 2Prongs	G/F" <input type="checkbox"/> 1u" <input type="checkbox"/> 3u" <input type="checkbox"/> 6u" <input type="checkbox"/>	黄铜 <input type="checkbox"/> Brass
		胶壳 Housing	1PCS	21*1451**	3叉 <input type="checkbox"/> 3Prongs	15u" <input type="checkbox"/> 30u" <input type="checkbox"/> 50u" <input type="checkbox"/> OTHER <input type="checkbox"/>	磷铜 <input type="checkbox"/> Phosphor copper
编号 NO.	名称 NAME	数量 QTY	料号 PART NO.	品名规格 DESCRIPTION		材质 MATERIAL	

产品编号 PRODUCT NO	11*1451****	品名规格 DESCRIPTION	FTP/CAT6/一件式/4上4下		页次 SHEET.	1/1
材质 MATERIAL	/	单位 UNIT	mm	比例 SCALE	1:1	图号 DWG NO
尺寸公差表 DIMENSIONAL TOLERANCE		第三视角法 THIRD ANGLE PROJECTION		制图 DRAWN	梁若彪	日期 DATE
X. X	±0.2			核对 CHECK		日期 DATE
X. XX	±0.10			批准 APPRO.		日期 DATE
X. XXX	±0.05					
ANGLE	±2°					